



SUGGESTED BASE PLATE FIXING

TIMBER FLOOR

If the base plate is not fitted flush with floor level, trim 12mm off inside leg of bottom tread (this could have been already done by us if requested).

Drill base plate in desired position and screw to trimmer which should be increased in width by bolting trimmers to each side of it.

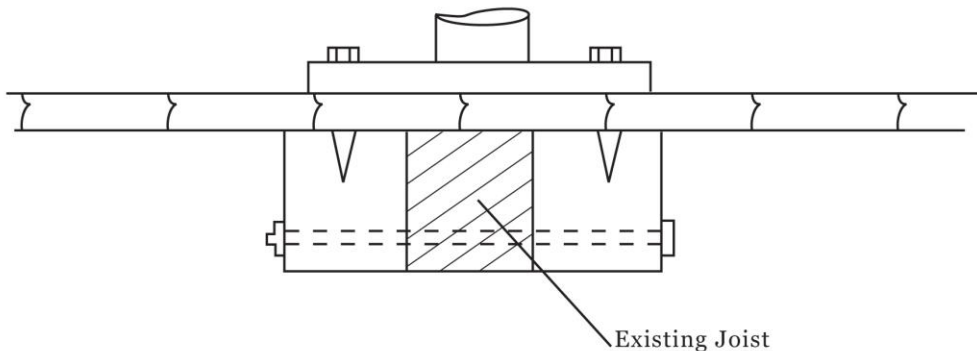

Alternative Fixes

- 1) If base plate can not be located on existing joist, fix trimmers at 90 degrees between joists.
- 2) Place piece of sheet steel across joist and bolt base plate to it.

Concrete Floor

Drill base plate in 3 places.

If base plate is not fitted flush see notes above.

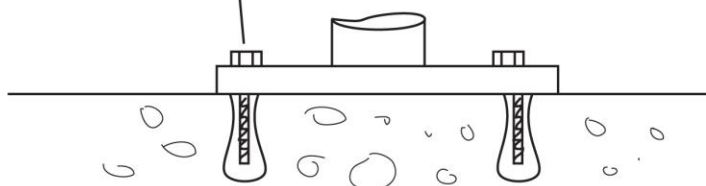

British Spirals & Castings

Peak Building, Eccles Rd, Chapel-en-le-Frith, High Peak, SK23 9RG

T +44(0)1663 750716 **E** sales@britishsc.co.uk **www.britishsc.co.uk**

A trading division of Harding Sales Ltd. Registered Office: Gorsty Low Farm, The Wash, Chapel-en-le-Frith, SK23 0QL. Company Registration Number: 7550371

A FOUNDING MEMBER OF
The Spiral Manufacturers Association